

L8542663

10/2016 rev 1

ONE.2WI
ONE.2WB
ONE.2WO



**ADVANTOUCH
READY**

ADVANCED-ROLLING-CODE

arc
128bit
SECURITY



BENINCA[®]
TECHNOLOGY TO OPEN

UNIONE NAZIONALE COSTRUTTORI
AUTOMATISMI PER CANCELLI, PORTE
SERRANDE ED AFFINI



ONE.2WI

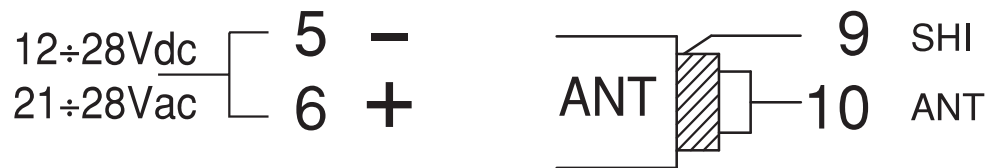
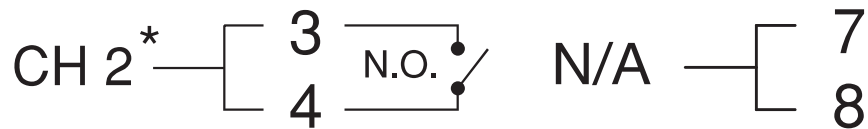
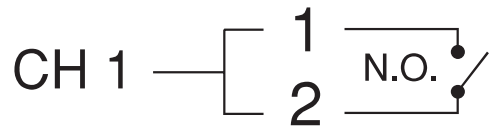
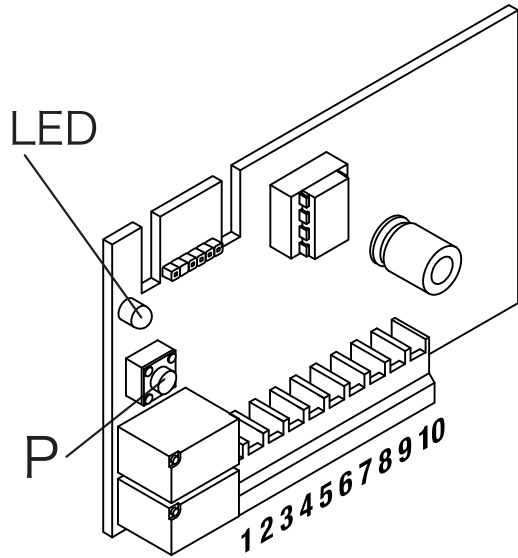

ONE.2WB

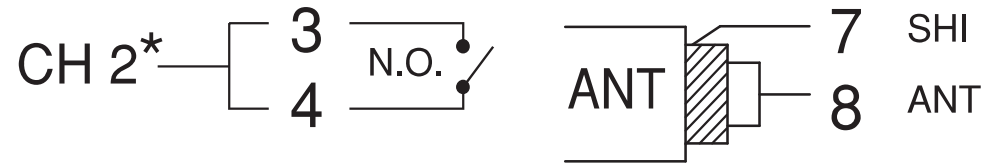
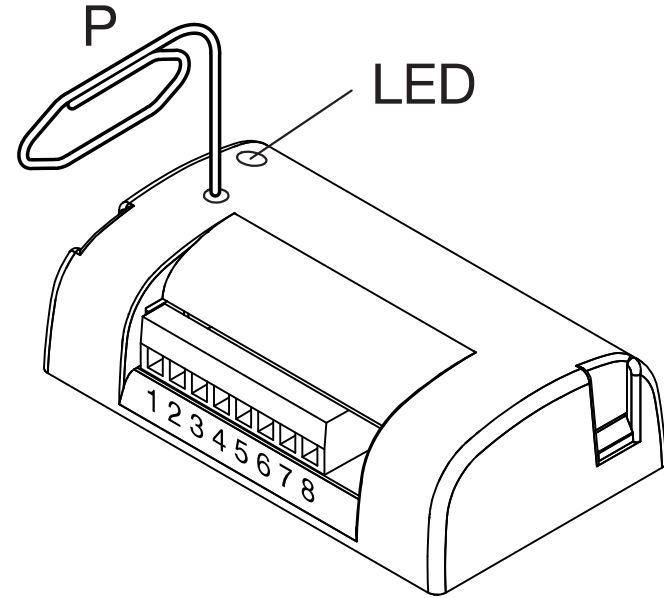

ONE.2W0

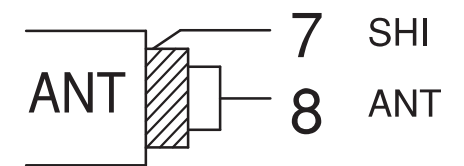
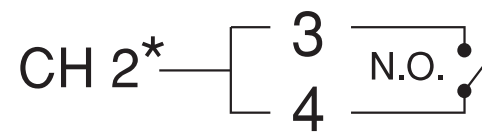
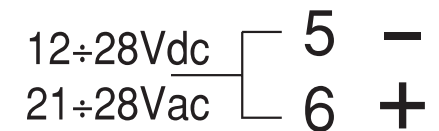
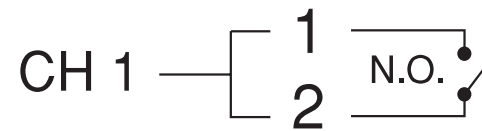
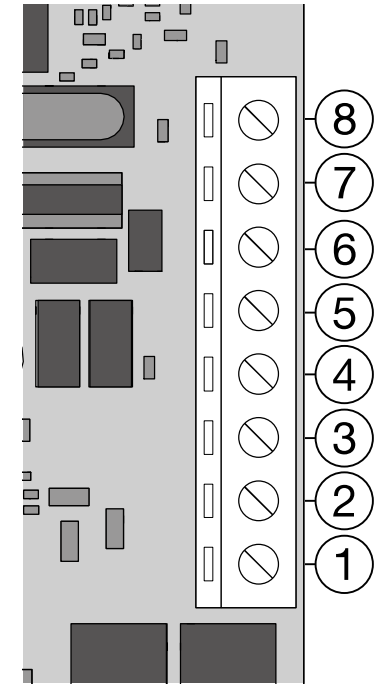
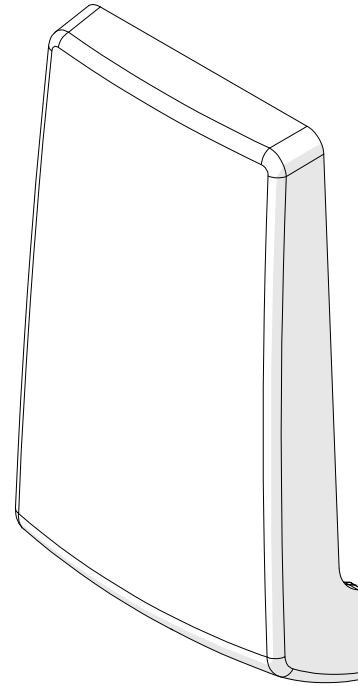
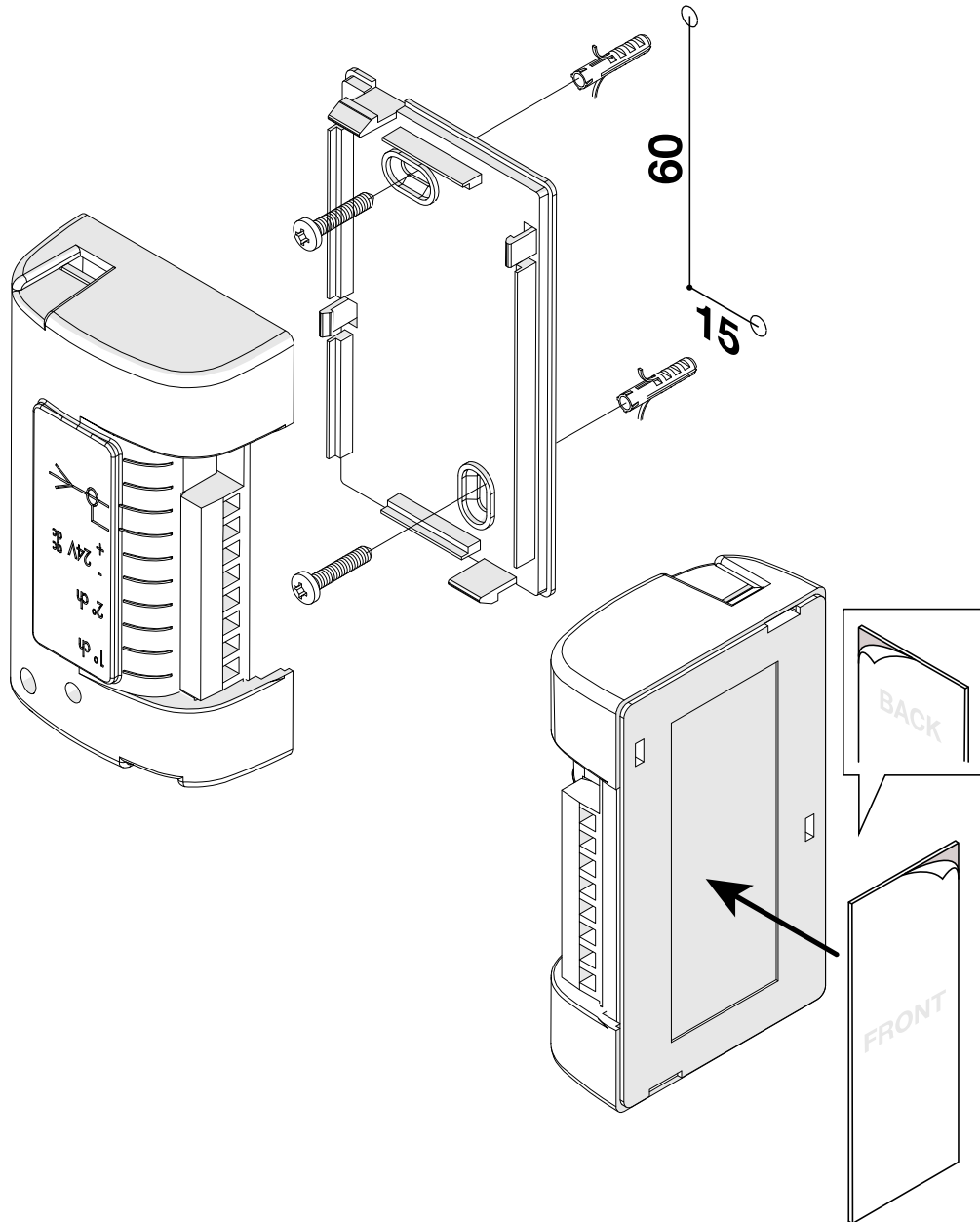

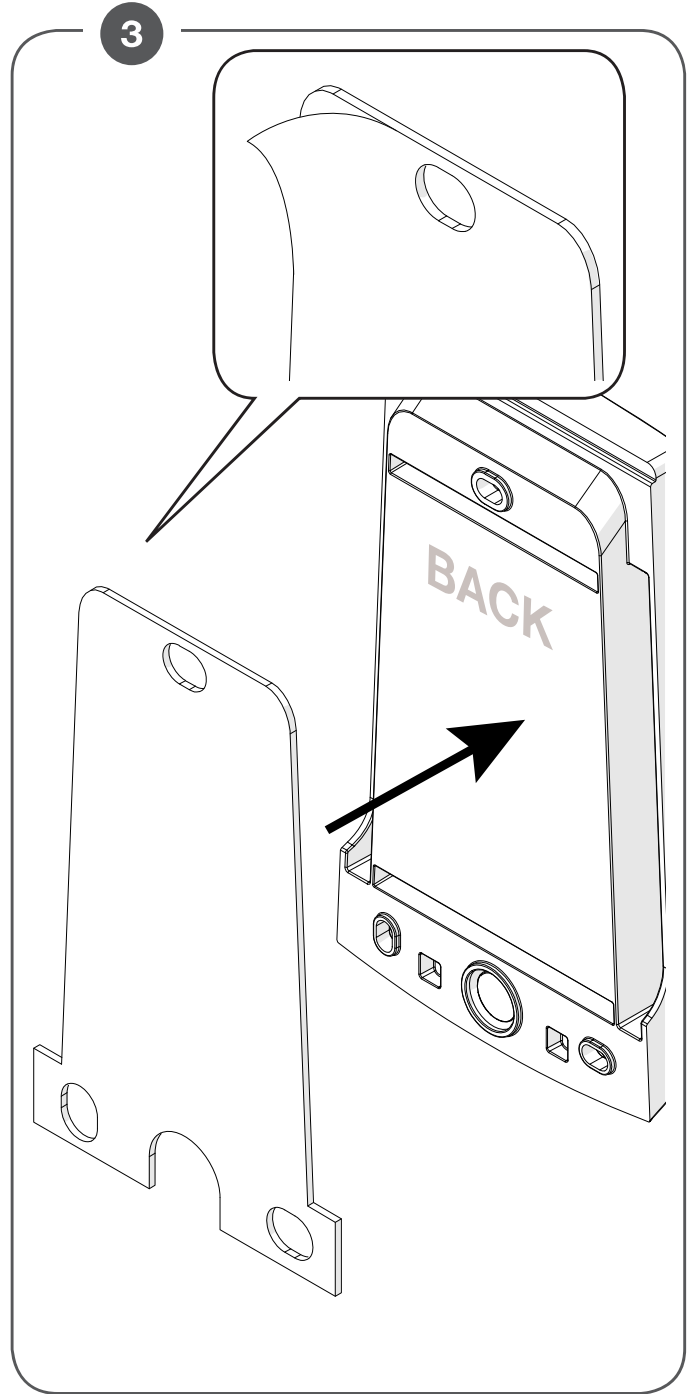
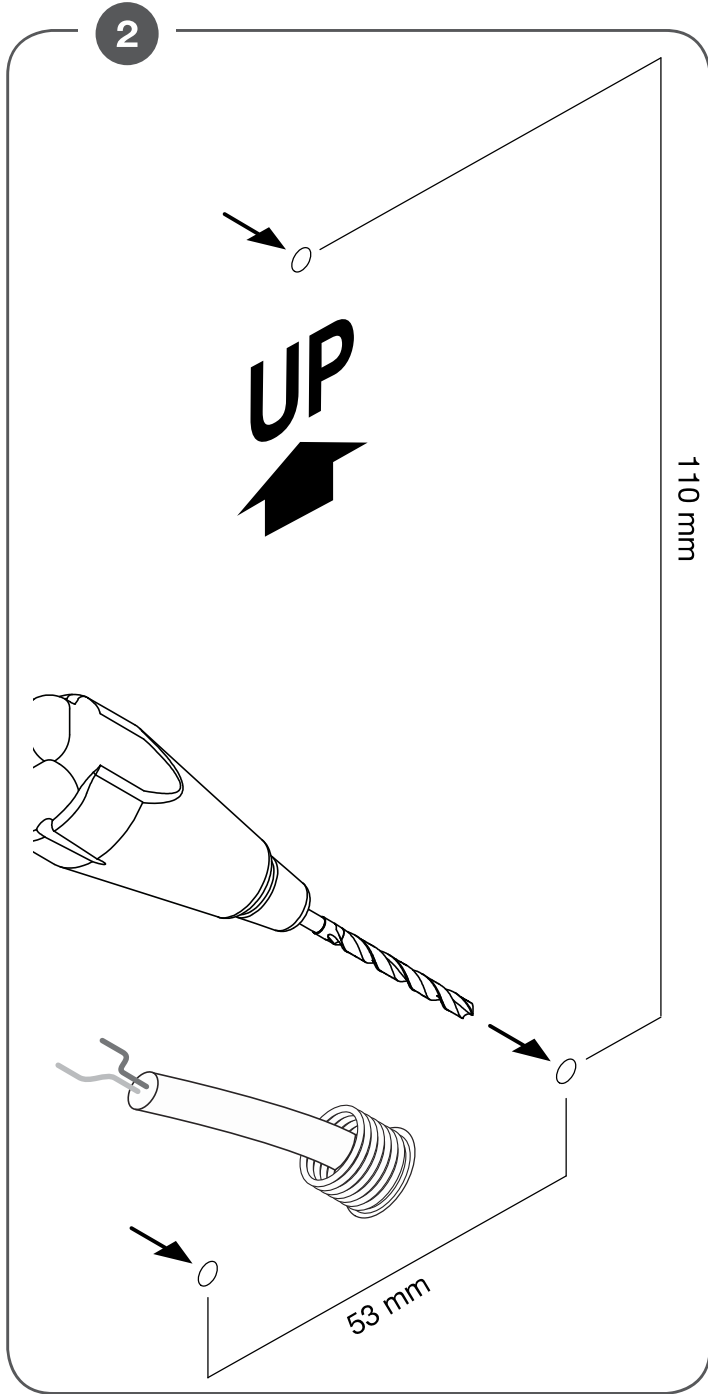
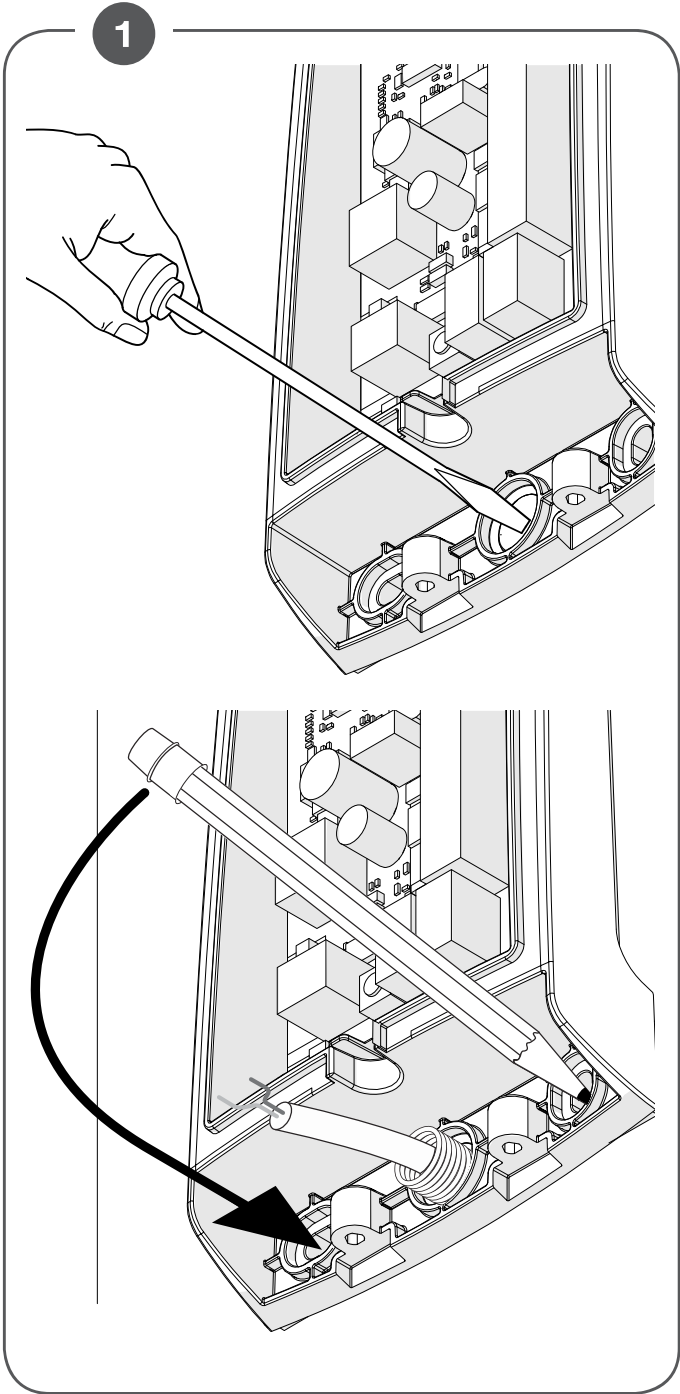

4

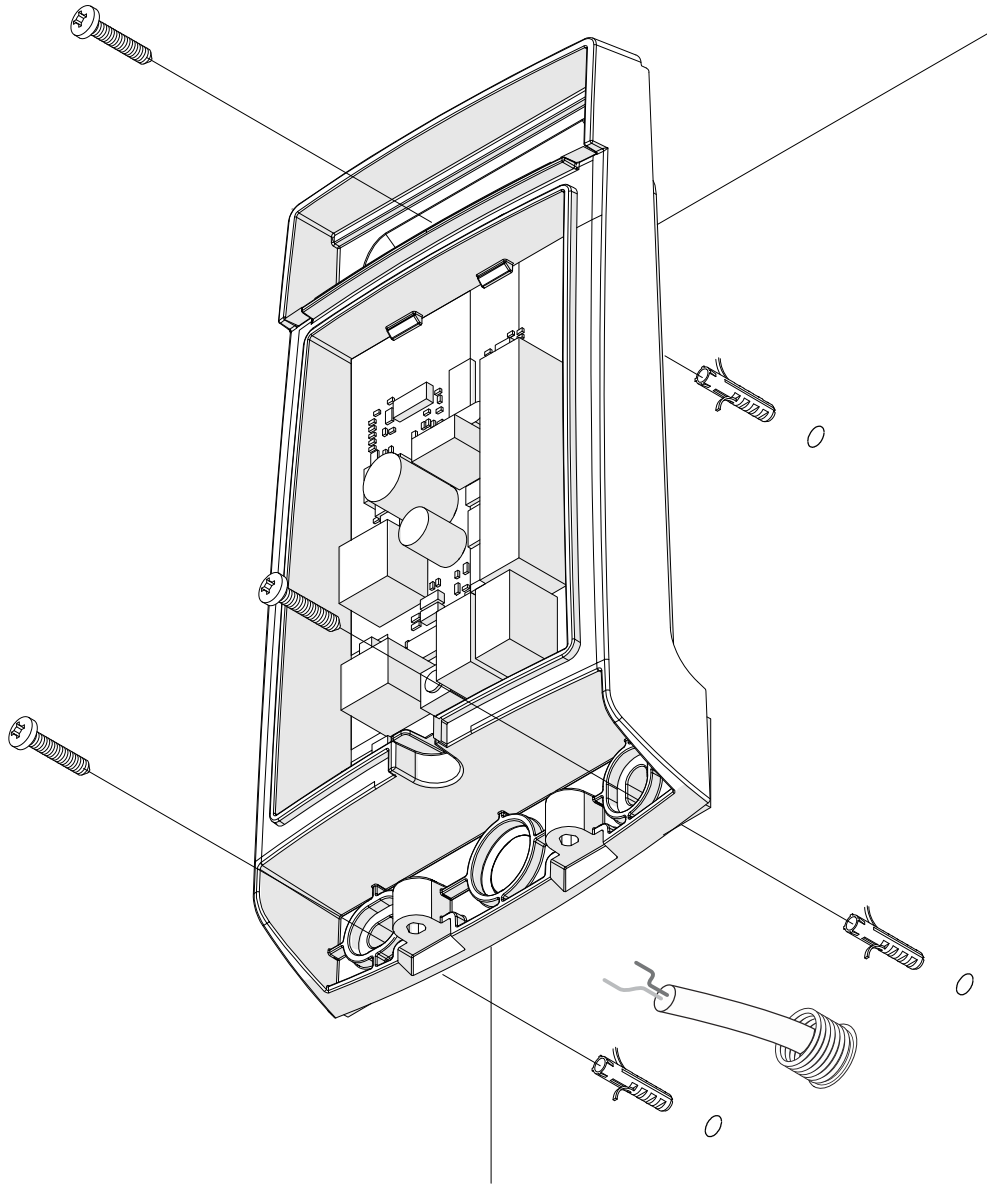

5

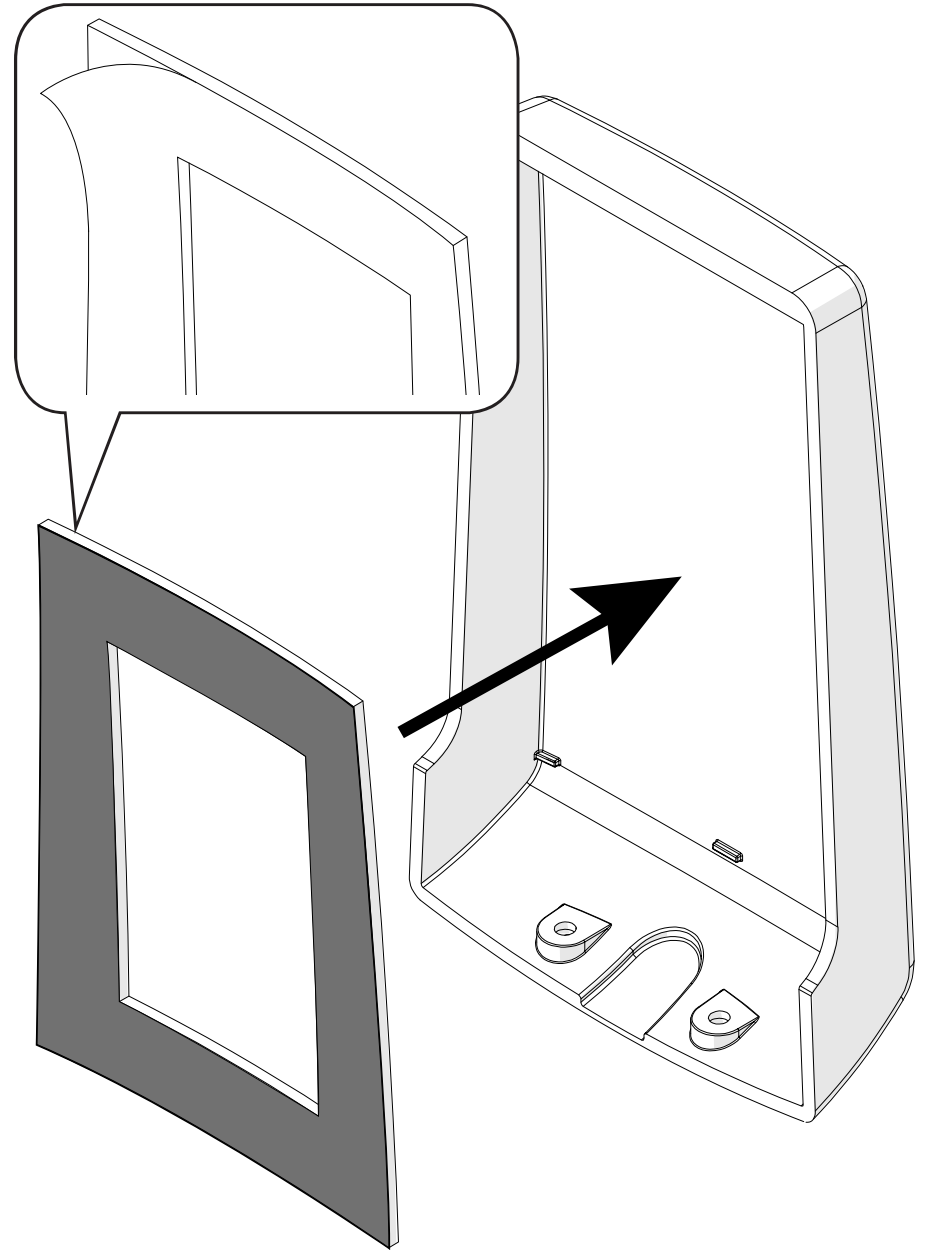

6

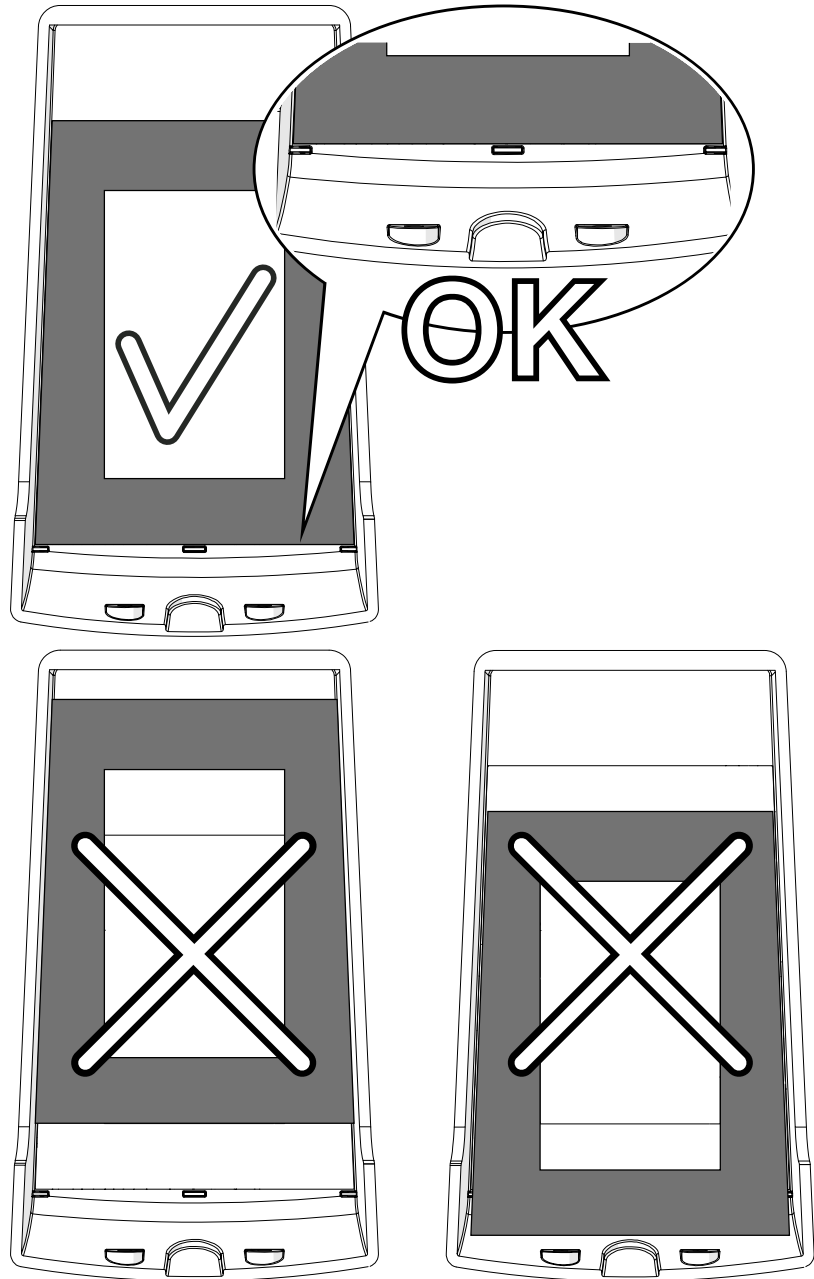

7

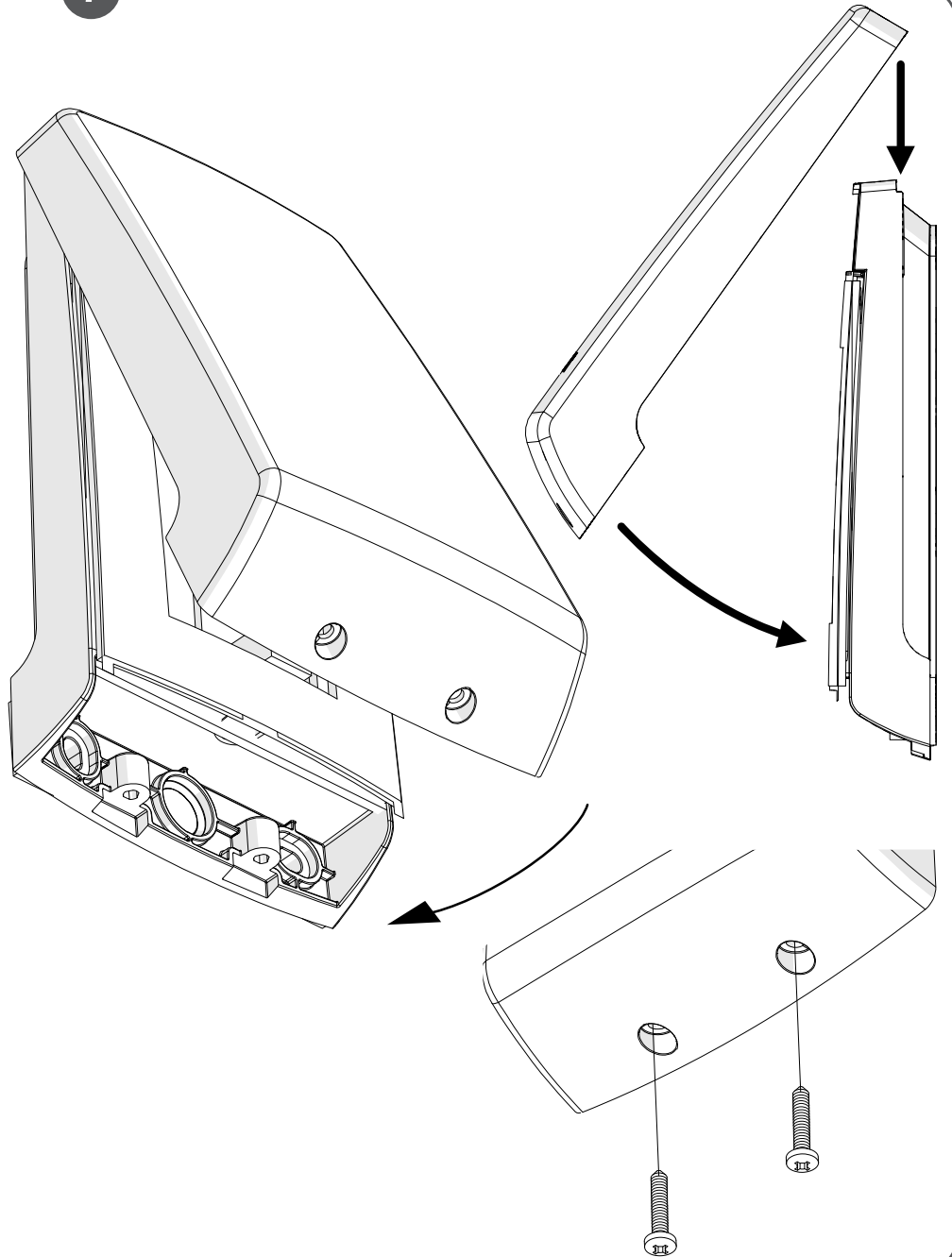

ENGLISH

433,92MHz Radioreceiver 1/2 channels, multiple decoding, compatible with Advantouch system.

They are available with Molex (ONE.2WI) socket or in a plastic box with terminal board (ONE.2WB) or in a plastic box for external use (ONE.2WO). The standard memory can contain 512 rolling-code, 433.92MHz, transmitters maximum. A special version is available with a memory that can hold 2048 transmitters. A full memory is indicated by 10 orange blinks.

N.B: The Advantouch palm programmer and related management software permit the use of certain advanced functions, please consult the relevant instruction manual for more information.

IMPORTANT:

The radio receiver ONE.2 is compatible with the new ARC (Advanced Rolling Code) transmitters which, thanks to 128-bit encryption ensure superior copy-security.

Storing new ARC transmitters is quite similar to that of normal rolling code transmitters with HCS coding, but be aware that:

- 1) ARC transmitters and Rolling Code HCS can not be stored in a single receiver.
- 2) The first transmitter memorized determines the type of transmitters to be used later. If the first transmitter memorized is ARC, you can not store Rolling code HCS transmitters, and vice versa.
- 3) Fixed code transmitters may only be used in conjunction with Rolling code HCS transmitters, bringing the logic (or dip / switch) CVAR OFF. They are, therefore, not usable in combination with the ARC transmitters. If the first rolling code transmitter stored is an ARC CVAR the logic is inoperative.
- 4) If you want to change the type of transmitters it is necessary to proceed with a receiver reset (as described in the manual).

To optimise reception install the antenna away from metal bodies and avoid positioning several receivers next to each other. If no antenna is used reception will be considerably reduced.

Memorising transmitters – Simplified procedure

To merely record one or more transmitters to activate the first channel, follow this simplified procedure:

- 1 Press and release the button P on the receiver.
- 2 The Red LED will light up for 3 secs, then go out for 1 sec and then light up again for 5 secs.
- 3 While the red LED is on, press the button on the transmitter to associate with channel 1.
- 4 Other transmitters can be then be recorded by pressing a button within 5 secs from recording the previous transmitter.
- 5 To end wait 5 secs, the receiver will exit programming.

Memorising a transmitter – Remote self-learning

If a transmitter has already been memorised on the receiver the remote radio self-learning feature can be used (without having to use the receiver button P). Proceed as follows:

- 1 Press the hidden button on the memorised transmitter.
- 2 Press, within 5 secs., the button on the memorised transmitter corresponding to the channel to associate with the new transmitter.
- 3 Press, within 5 secs., the button on the new transmitter to associate with the channel selected at point 2 above.
- 4 The receiver will memorise the new transmitter and promptly exit programming.

TABLE 1

Mode	LED	Function	Operations
0	Off	No function	Normal status.
Press the button P			
1	Red	Memorise channel 1	The red LED will light up, wait 3 secs, the LED will go out and light up again, press within 5 secs the button on the transmitter to associate with channel 1.*
Press within 3 secs the button P			
2	Green	Memorise channel 2	The green LED will light up, wait 3 secs, the LED will go out and light up again, press within 5 secs the button of the transmitter to associate with channel 2.*
Press within 3 secs the button P			
3	Orange	Memorise automatically channels 1 and 2	The orange LED will light up, wait 3 secs, the LED will go out and light up again, press within 5 secs any button on the transmitter. Button 1 will be associated with channel 1, button 2 with channel 2.*
Press within 3 secs the button P			
4	Red Blinking	Set channel 1 times	The LED will give 5 rapid blinks. If button P is pressed during these 5 blinks the next mode is entered. After the 5 rapid blinks the Times menu is entered. See section "Times Mode"
Press within 3 secs the button P			
5	Green Blinking	Set channel 2 times	The LED will give 5 rapid blinks. If button P is pressed during these 5 blinks the next mode is entered. After the 5 rapid blinks the Times menu is entered. See section "Times Mode"
Press within 3 secs the button P			
0	LED Off	No function	Normal status.

Programming

Transmitters can be memorised and separate channel modes can be set using the button “P” (see Fig.1/2). To go from one programming mode to the next press the button P within 3 secs from one press and another. Once having selected a programming mode, wait for about 3-4 secs and a LED signal will indicate that programming has been entered (see “Operations” column).

Table 1 lists the various programming modes.

** After pressing the button on the first transmitter the receiver will wait 5 secs to memorise another transmitter.*

In this way all the transmitters being associated with one channel can be recorded in sequence. After the 5 secs the receiver exits the programming mode. When using this method of recording in sequence it is best to temporarily remove the antenna thereby reducing the receiver’s range and limiting disturbance.

N.B.: Once a programming mode has been entered, other modes cannot be accessed. When programming several functions complete one programming sequence, indicated by the LED going out, and restart with a new programming mode.

TABLE 2			
Mode	LED	Function	Operazioni
1	1 rapid blink	Set pulse mode	If the P button is not pressed within 5 secs the channel is reset to the default pulse mode (1 sec switching).
Press the button P for at least 2 secs			
2	2 rapid blinks	Select switching time	If the P button is not pressed within 5 secs the LED will start blinking at a rate of 1 blink/sec until the button P is pressed. The number of blinks counted before pressing the P button selects the switching time, as shown in table 3.
Press the button P for at least 2 secs			
3	3 rapid blinks	Set Bistable mode	If the P button is not pressed within 5 secs the channel is set to the bistable mode: the relay changes status on each pulse.
Press the button P for at least 2 secs			
4	Off	No function	Normal status.

TABLE 3

LED Blinks	Switching Time	LED Blinks	Switching Time	LED Blinks	Switching Time	LED Blinks	Switching Time
1	1s	9	9s	17	3,5m	25	5m
2	2s	10	10s	18	4m	26	6m
3	3s	11	30s	19	4,5m	27	7m
4	4s	12	60s	20	5m	28	8m
5	5s	13	1,5m	21	1m	29	9m
6	6s	14	2m	22	2m	30	10m
7	7s	15	2,5m	23	3m		
8	8s	16	3m	24	4m		

Times Mode

This function is only necessary when one of the two channels has to be set to be timed (from 1 sec to 10 min) or with bistable operation. The pulse operating mode is set by default (1 sec switching). To set the times enter mode 4 (for channel 1) or mode 5 (for channel 2) and wait until the end of the 5 rapid blinks. The Times submenu is described in table 2.

Resetting the memory

Cut off the power to the receiver. Press and keep pressed the button P. Restore the power keeping the button P pressed. The LED will light up red, after 5 secs it will blink rapidly alternating green-red, release the button. Wait for the LED to go out. The memory is now completely erased.

Technical Characteristics	ONE.2WB/WI/WO
Frequency	433,92 MHz
Power supply	21÷28 Vac 12÷28 Vdc
Range	Without antenna 30m with antenna 100m
Channels	2
Relay contact	1A/24 Vdc
Working temperature	-20/+70°C
Consumption in standby	10 mA
Consum. ch. 1 or 2 actuated	42 mA
Consum.ch. 1 and 2 actuated	66 mA

Dichiarazione di Conformità UE (DoC)

Nome del produttore: **Automatismi Benincà SpA**

Indirizzo: **Via Capitello, 45 - 36066 Sandrigo (VI) - Italia**

Telefono: **+39 0444 751030**

Indirizzo e-mail: **sales@beninca.it**

Persona autorizzata a costruire la documentazione tecnica: **Automatismi Benincà SpA**

Tipo di prodotto: **Radioricevitore con frequenza 433,92MHz**

Modello/Tipo: **ONE.2WI/ONE.2WB/ONE.2WO** Accessori: **N/A**

Il sottoscritto Luigi Benincà, in qualità di Responsabile Legale, dichiara sotto la propria responsabilità che il prodotto sopraindicato risulta conforme alle disposizioni imposte dalle seguenti direttive:

Direttiva 2014/30/UE (EMCD), secondo le seguenti norme armonizzate: EN 61000-6-2:2005, EN 61000-6-3:2007.

Direttiva 2011/65/UE (RoHS), secondo le seguenti norme armonizzate: EN 50581:2012

Direttiva 1999/5/CE (R&TTE), secondo le seguenti norme armonizzate: ETSI EN 301 489-3 V1.4.1 (2002) + ETSI EN 301 489-1 V1.4.1 (2002) + ETSI EN 300 220-3 V1.1.1 (2000) + EN 60950-1 (2001)

Benincà Luigi, Responsabile legale.
Sandrigo, 19/10/2016.



Il Certificato di Conformità di questo documento corrisponde all'ultima revisione disponibile al momento della stampa e può risultare differente per esigenze editoriali dall'originale disponibile presso il produttore.

Il Certificato di Conformità più completo e recente è disponibile consultando il sito: www.beninca.com oppure può essere richiesto presso: Automatismi Benincà S.p.A - Sandrigo VI - Italy.

UE Declaration of Conformity (DoC)

Manufacturer's name: **Automatismi Benincà SpA**

Address: **Via Capitello, 45 - 36066 Sandrigo (VI) - Italia**

Telephone: **+39 0444 751030**

Email address: **sales@beninca.it**

Person authorised to draft the technical documentation: **Automatismi Benincà SpA**

Product type: **433,92MHz frequency radioreceiver**

Model/type: **ONE.2WI/ONE.2WB/ONE.2WO** Accessories: **N/A**

The undersigned Luigi Benincà, as the Legal Officer, declares under his liability that the aforementioned product complies with the provisions established by the following directives:

Directive 2014/30/UE according to the following harmonised regulations: EN 61000-6-2:2005, EN 61000-6-3:2007 + A1:2011.

Directive 2011/65/EU according to the following standards: EN 50581:2012

Directive 1999/5/CE according to the following harmonised standards: ETSI EN 301 489-3 V1.4.1 (2002) + ETSI EN 301 489-1 V1.4.1 (2002) + ETSI EN 300 220-3 V1.1.1 (2000) + EN 60950-1 (2001)

Benincà Luigi, Legal Officer.
Sandrigo, 19/10/2016.



The certificate of conformity in this document corresponds to the last review available at the time of printing and could differ for editorial requirements from the original available from the manufacturer.

The most recent and complete certificate of conformity is available consulting the site: www.beninca.com or can be requested from: Automatismi Benincà SpA - Sandrigo VI - ITALY.

BENINCA[®]

AUTOMATISMI BENINCÀ SpA

Via Capitello, 45 - 36066 Sandrigo (VI) - Tel. 0444 751030 r.a. - Fax 0444 759728
